

■ Features

- ◆ High output power of 70W
- ◆ 200 μ m/0.22NA multimode optical fiber
- ◆ Center wavelength 878.6 \pm 0.5nm

■ Applications

- ◆ Fiber laser pumping
- ◆ Direct diode laser applications

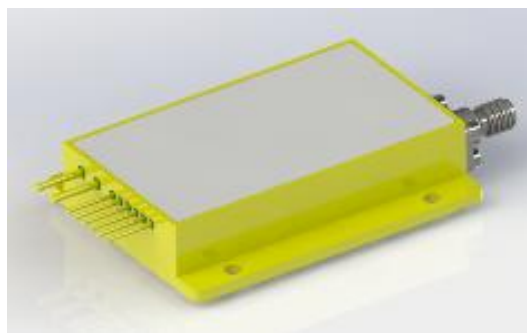

Outline Dimension (mm)

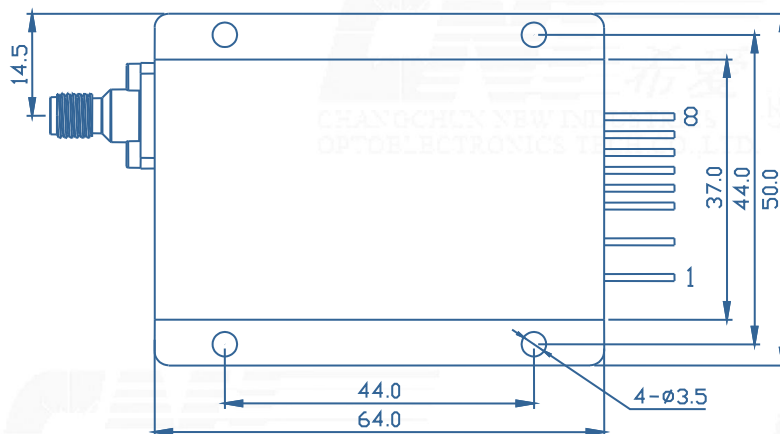
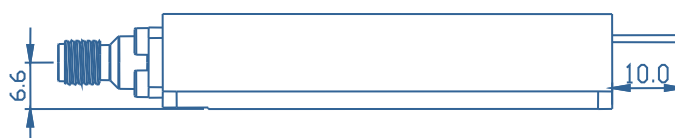
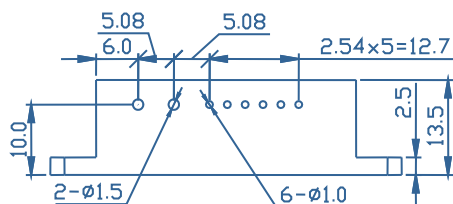

Pin-Out Assignment	
Pin	Function
1	LD (+)
2	LD (-)
3	-
4	-
5	PD (N)
6	PD (P)
7	Thermistor
8	Thermistor

Typical Device Performance (25°C)

	Min	Typical	Max	Unit
Optical				
CW Output Power	-	70	-	W
Center Wavelength	-	878.6±0.5	-	nm
Spectral Width (FWHM)	-	<0.8	-	nm
Wavelength Shift with Temperature	-	0.02	-	nm / °C
Wavelength Shift with Current	-	0.05	-	nm / A
Feedback Protection (1030-1100nm)	-	>40	-	dB
Power within 0.18 NA	-	>95%	-	-
Electrical				
Threshold Current	-	1.5	-	A
Operating Current	-	11.8	13.0	A
Operating Voltage	-	12.3	14.0	V
Slope Efficiency	-	6.8	-	W / A
Power Conversion Efficiency	43	48	-	%
Fiber*				
Fiber Core Diameter	-	200	-	μm
Fiber Cladding Diameter	-	220	-	μm
Fiber Buffer Diameter	-	500	-	μm
Numerical Aperture	-	0.22	-	-
Fiber Length	-	1-5	-	m
Fiber Connector	-	SMA905	-	-

* Customized fiber and connector available.

Absolute Ratings

	Min	Max	Unit
Operating Temperature	15	35	°C
Operating Relative Humidity	-	75	%
Cooling Mode	-	Water cooling (25°C)	-
Storage Temperature	-20	80	°C
Storage Relative Humidity	-	90	%
Lead Soldering Temperature (10 s max)	-	250	°C

* Measuring specifications.

All figures in this specification are measured by CNI's method and may contain measurement deviations.

The above specifications are for reference purpose only and subjected to change without prior notice.



Changchun New Industries Optoelectronics Tech. Co., Ltd
<http://www.cnilaser.com>

◆ CONTACT

No.888, JinHu Road, High-tech zone, Changchun
 130103, R.P. China

Phone: 0086-431-85603799

Fax: 0086-431-87020258