

MGL-H-532/500~1500mW

LD PUMPED ALL-SOLID-STATE GREEN LASER

All solid state 532nm green laser is made features of ultra compact, long lifetime and easy operating, which is widely used in collimation, laser medical treatment, scientific experiment, optical instrument, laser display, laser lighting show, etc.



SPECIFICATIONS

Wavelength (nm)	532±1	
Output power (mW)	> 500, 600, ..., 1400	1500
Transverse mode	Near TEM ₀₀	
Operating mode	CW	
Power stability (rms, over 4 hours)	<5%, <10%	
Warm-up time (minutes)	<10	
Beam divergence, full angle (mrad)	<2.0	<1.0
Beam diameter at the aperture (mm)	~3.0	~4.0
Beam height from base plate (mm)	29	
Operating temperature (°C)	10~35	
Power supply (90-264VAC)	PSU-H-OEM	PSU-F-HS
Modulation option	TTL on/off, 1Hz-1KHz, 1KHz-10KHz, 10KHz-30KHz; and Analog modulation option	
Expected lifetime (hours)	10000	
Warranty period	1 year	

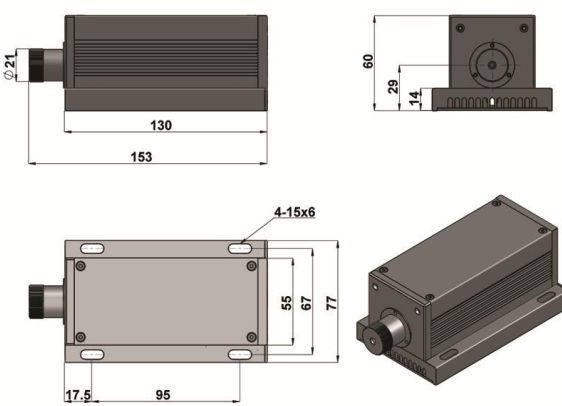
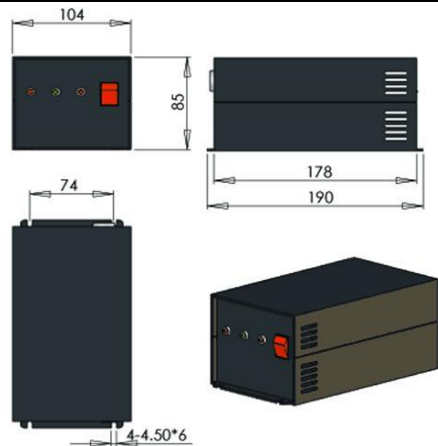
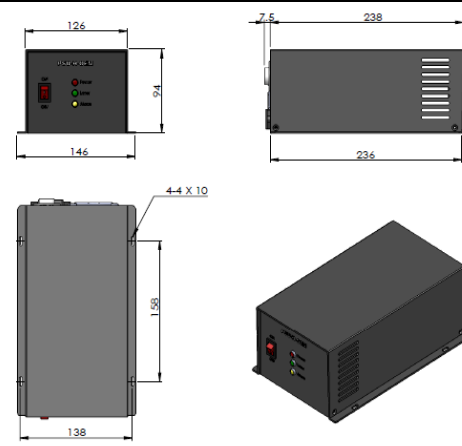

Dimensions of Laser head	Supply Power(1W)	Supply Power(1W)
 <p>MGL-H-532 153(L)×77(W) ×60(H) mm³, 0.9kg</p>	 <p>PSU-H-OEM-S 190(L)×104(W) ×85(H) mm³, 0.8kg</p>	 <p>PSU-H-OEM 236(L)×146(W) ×94(H) mm³, 1.2kg</p>

Supply power(1W)

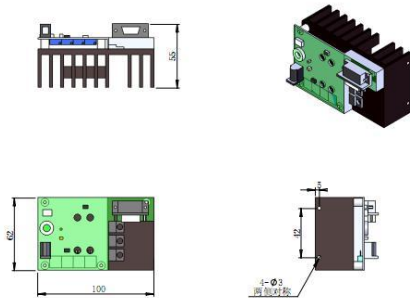

PSU-III-OEM

100(L)×62(W) ×55(H) mm³, 0.6kg

Adapter(1W)

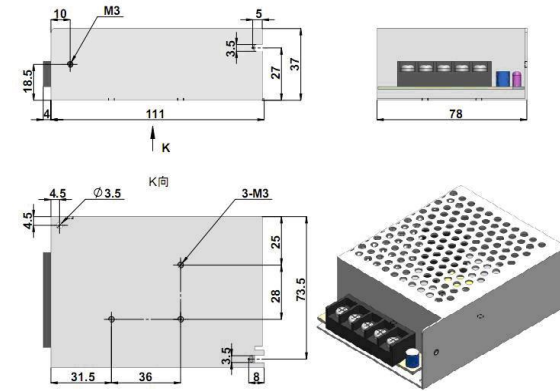

6.5V8A

111(L)×78(W) ×37(H) mm³, 0.5kg

Supply power(1.5W)

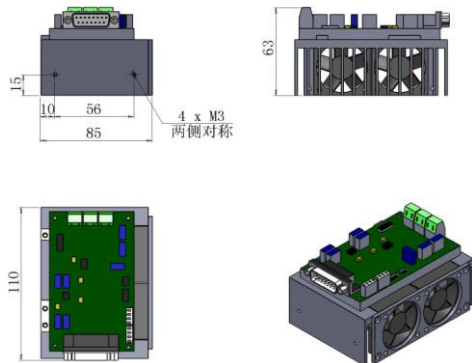

PSU-F-HS (1.5W)

110(L)×85(W) ×63(H) mm³, 0.6kg

Adapter (1.5W)

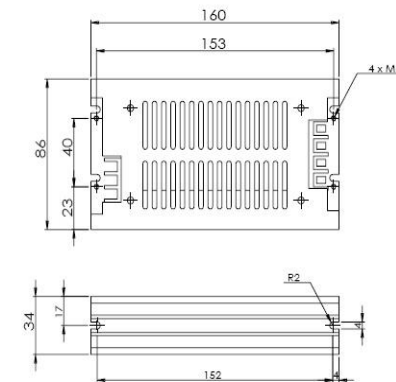

10V8A 6.5V8A

160(L)×86(W) ×34(H) mm³, 0.5kg