



MSL-III-523.5/1~50mW



**SINGLE LONGITUDINAL MODE  
GREEN LASER AT 523.5nm**

All solid state single longitudinal mode green laser at 523.5nm is made features of ultra compact, long lifetime, low cost and easy operating, which is used in DNA sequencing, flow cytometry, cell sorting, optical instrument, spectrum analysis, interference, measurement, holography, laser printing, chip inspection, brillouin scattering, physics experiment, etc.



**SPECIFICATIONS**

|   |                         |
|---|-------------------------|
| Wavelength (nm)                                       | 523.5                   |
| Operating mode  | CW                      |
| Output power (mW)                                     | >1, 5, 10, 20, ... , 50 |
| Power stability (rms, over 4 hours)                   | <2%, <3%, <5%           |
| Transverse mode                                       | TEM <sub>00</sub>       |
| Longitudinal mode                                     | Single                  |
| Spectral linewidth (nm)                               | <0.00001                |
| Coherent length (m)                                   | >50                     |
| Noise of amplitude (rms, 1Hz~20MHz)                   | <1%, typical<0.5%       |
| M <sup>2</sup> factor                                 | <1.2                    |
| Beam diameter at the aperture (1/e <sup>2</sup> , mm) | <1.2                    |
| Beam divergence, full angle (mrad)                    | <1.5                    |
| Warm-up time (minutes)                                | <10                     |
| Pointing stability after warm-up (mrad)               | <0.05                   |
| Beam height from base plate (mm)                      | 24.8                    |
| Operating temperature (°C)                            | 15~35                   |
| Power supply (90-264VAC or 5VDC)                      | PSU-III-FDA             |
| Expected lifetime (hours)                             | 10000                   |
| Warranty  | 1 year                  |



MSL-III-523.5

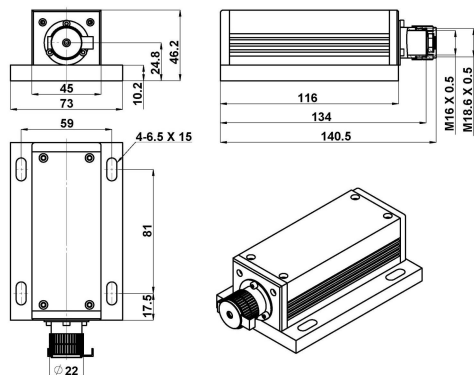

140.5 (L) × 73 (W) × 46.2 (H) mm<sup>3</sup>, 0.6kg

PSU-III-FDA

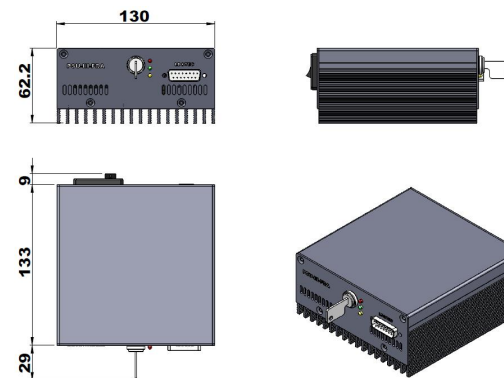

171 (L) × 130(W) × 62.2 (H) mm<sup>3</sup>, 1.2kg