



FC-D-514.5/1~20mW



**GREEN DIODE LASER FOR  
RAMAN SPECTROSCOPY  
AT 514.5nm**

With narrow spectral bandwidth, spectral purity and a high level of wavelength stability, FC-D-514.5 laser module is designed specially for Raman spectroscopy, which has integrated laser drivers and thermoelectric coolers together, its compact dimension and convenient functions make it optimal for industrial and medical applications.



SPECIFICATIONS

Model	FC-D-514.5 (Spectrum Stabilized for Raman spectroscopy)	
Central wavelength (nm)	514.5±0.5	
Spectral line width (nm)	0.1 (0.06, optional)	
Operating mode	CW	
Fiber core diameter	100µm, 0.22 NA	
Fiber connector	SMA905	
Output power after fiber (mW)	>1, 2, ..., 20	
Power stability (rms, over 4 hours)	<3%, <2%, <1%	
Central wavelength stability (rms, over 2 hours) (pm)	<10	
Noise of amplitude (rms, 1~20MHz)	<1%	
Warm-up time (minutes)	<5	
Operating temperature (°C)	20~30	
Power supply	Adaptor(100-240VAC)	5VDC@5A
Expected lifetime (hours)	10000	
Warranty	1 year	

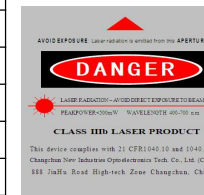

FC-D-514.5

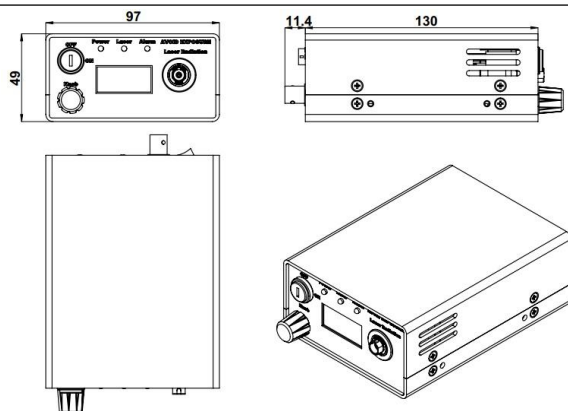

141.4(L)×97(W)×49(H) mm<sup>3</sup>, 1.0kg

Accessory(Adaptor)

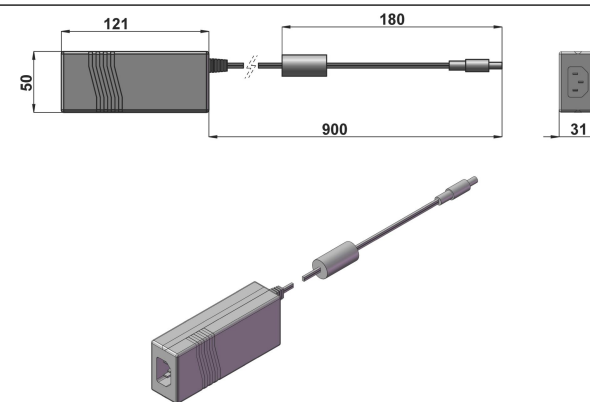

121(L)×50(W)×31(H) mm<sup>3</sup>, 0.3kg