

FL-1064/ 300μJ/6W



### FL SERIES 1064nm LASER SOURCE FOR LASER MARKING

FL-1064nm series laser combination of both DPSS and fiber technology, has the features of high peak power, high repetition rate, and short pulse duration, which is widely used in laser marking, engraving on the diamond, metal, Steel, IC, Plastics, and also in scientific research.



#### SPECIFICATIONS

Wavelength (nm)	1064±1
Operating mode	Passively Q-switched
Average power (W)	~6
Single pulse energy (μJ)	~300
Pulse duration (ns)	~6
Peak power (kW)	~50
Rep. rate (kHz)	10~20kHz, Suitable for the applications of needing high peak power.
Power stability (over 8 hours)	<1%, <2%, <3%, <5%
Transverse mode	TEM <sub>00</sub>
Beam divergence, full angle (mrad)	<1.5
Beam diameter at the aperture (1/e <sup>2</sup> , mm)	~6.0
Warm-up time (minutes)	<10
Beam height from base plate (mm)	16.5
Operating temperature (°C)	0~40
Power supply (12VDC)	PSU-FL-FDA ( switching power supply 12V/25A DC, choosed, )
Expected lifetime (hours)	20000
Warranty period	1 year



FL-1064 (N)

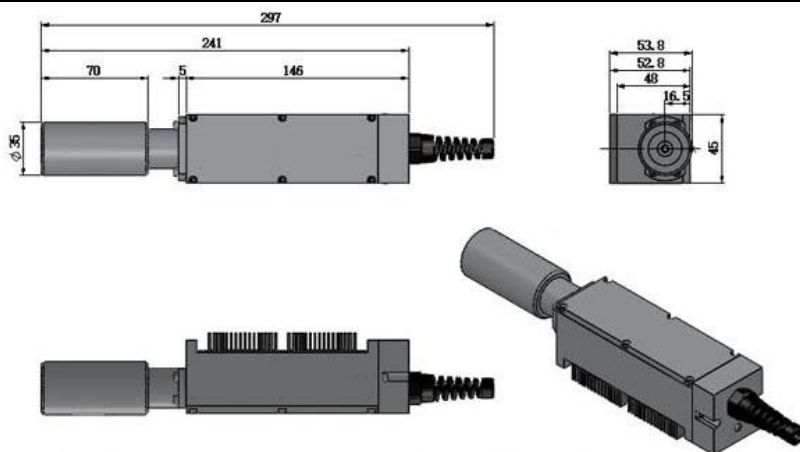

297 (L) ×45 (W) ×53.8 (H) mm<sup>3</sup>, 0.7 kg

PSU-FL-FDA

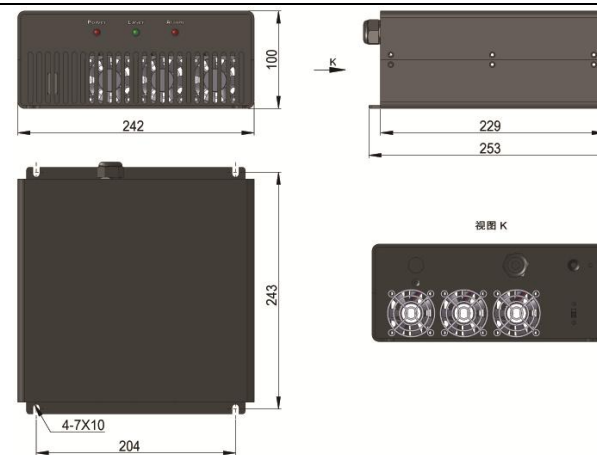

253 (L) ×242 (W) ×100 (H) mm<sup>3</sup>, 3.6 kg