

■ Features

- ◆ High output power of 15W
- ◆ 200 μ m/0.22NA multimode optical fiber
- ◆ Center wavelength 1470 \pm 10nm

■ Applications

- ◆ Medical Application

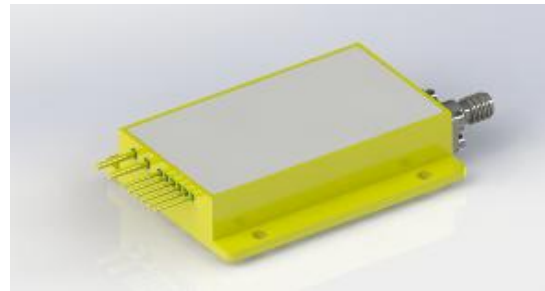

Outline Dimension (mm)

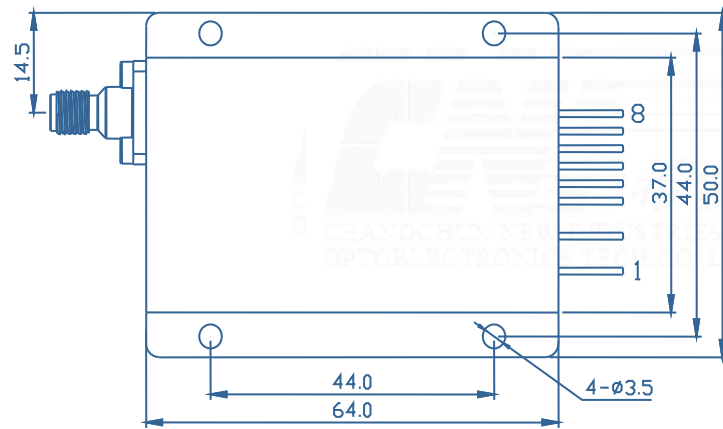
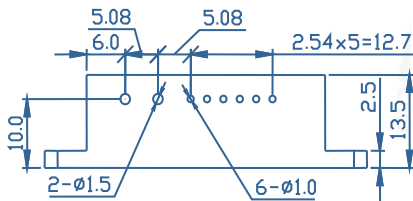

Pin-out Assignment

Pin	Function
1	LD (+)
2	LD (-)
3	PD(N)
4	PD(P)
5	Thermistor
6	Thermistor
7	Aiming Beam (+5V)*
8	Aiming Beam (0V)

Typical Device Performance (25°C)

	Min	Typical	Max	Unit
Optical				
CW Output Power	-	15	-	W
Center Wavelength	-	1470±10	-	nm
Spectral Width (90% of Power)	-	<10.0	-	nm
Wavelength Shift with Temperature	-	0.3	-	nm / °C
Electrical				
Threshold Current	-	0.4	-	A
Operating Current	-	6.9	-	A
Operating Voltage	-	9.5	-	V
Slope Efficiency	-	2.3	-	W / A
Power Conversion Efficiency	-	22.5	-	%
Aiming laser				
CW Output Power	-	2	-	mW
Center Wavelength	-	650±10	-	nm
Operating Current	-	<30	-	mA
Operating Voltage	-	5	-	V
Fiber*				
Fiber Core Diameter	-	200	-	μm
Fiber Cladding Diameter	-	220	-	μm
Fiber Buffer Diameter	-	500	-	μm
Numerical Aperture	-	0.22	-	-
Fiber Length	-	1-5	-	m
Fiber Connector	-	SMA905	-	-

* Customized fiber and connector available.

Absolute Ratings

	Min	Max	Unit
Operating Temperature	15	35	°C
Operating Relative Humidity	-	75	%
Cooling Mode	-	Water cooling (25°C)	-
Storage Temperature	-20	80	°C
Storage Relative Humidity	-	90	%
Lead Soldering Temperature (10 s max)	-	250	°C

* Measuring specifications.

All figures in this specification are measured by CNI's method and may contain measurement deviations.

The above specifications are for reference purpose only and subjected to change without prior notice.

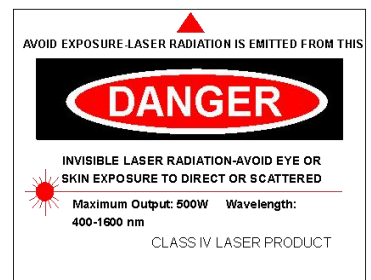

Changchun New Industries Optoelectronics Tech. Co., Ltd
<http://www.cnilaser.com>

◆ CONTACT

No.888, JinHu Road, High-tech zone, Changchun
130103, R.P. China

Phone: 0086-431-85603799

Fax: 0086-431-87020258