

520nm Laser Diode

■ Features

- ◆ High output power of 4W
- ◆ 200 μ m/0.22NA multimode optical fiber
- ◆ Center wavelength 520 \pm 10nm

■ Applications

- ◆ Scientific Research Application
- ◆ Lighting

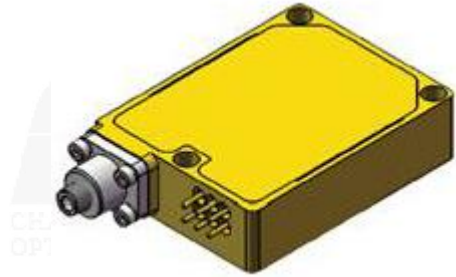

Outline Dimension (mm)

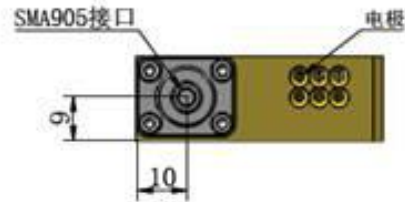
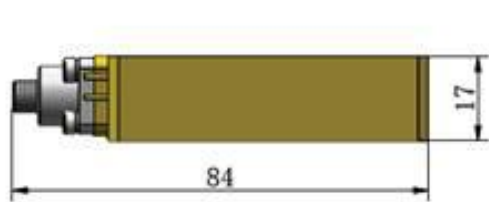

Pin-out Assignment	
Pi	Function
1	LD (+)
2	LD (-)
3	Thermistor
4	Thermistor
5	-
6	-
7	-
8	-

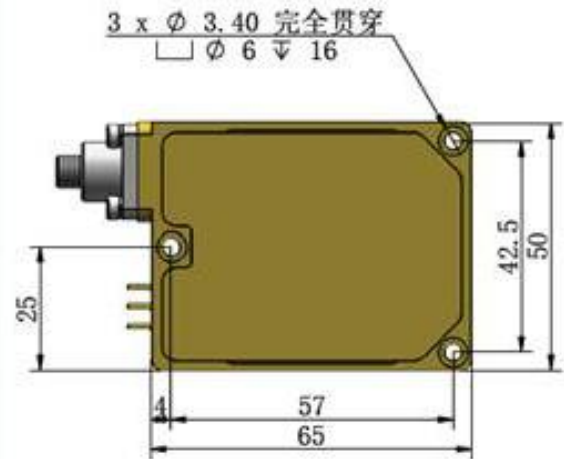

Typical Device Performance (20°C)

	Min	Typical	Max	Unit
Optical				
CW Output Power	-	4	-	W
Center Wavelength	-	520±10	-	nm
Spectral Width (90% of Power)	-	4.0	-	nm
Electrical*				
Threshold Current	-	-	0.50	A
Operating Current	-	1.9	2	A
Operating Voltage (Simplex)	-	20	-	V
Fiber*				
Fiber Core Diameter	-	200	-	µm
Numerical Aperture	-	0.22	-	-
Fiber Length	-	1-5	-	m
Fiber Connector	-	FC/SMA905	-	-
Fiber Armor	-	Optional	-	-
Fiber Minimum Bending Diameter	75	-	-	mm

Absolute Rating

	Min	Max	Unit
Operating Temperature	15	35	°C
Operating Relative Humidity	-	75	%
Storage Temperature	-20	80	°C
Storage Relative Humidity	-	90	%
Lead Soldering Temperature (10 s max)	-	250	°C

* Measuring specifications.

All figures in this specification are measured by CNI's method and may contain measurement deviations.

The above specifications are for reference purpose only and subjected to change without prior notice.

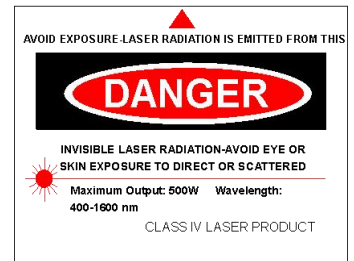

Changchun New Industries Optoelectronics Tech. Co., Ltd
<http://www.cnilaser.com>

◆ CONTACT

No.668, Chuangxin Road, High-tech zone,
 Changchun 130012, China

Phone: 0086-431-85603799

Fax: 0086-431-87020258