

520nm Laser Diode

■ Features

- ◆ High output power of 70W
- ◆ 200 μ m/0.22NA multimode optical fiber
- ◆ Center wavelength 520 \pm 10nm

■ Applications

- ◆ Industrial processing
- ◆ Lighting

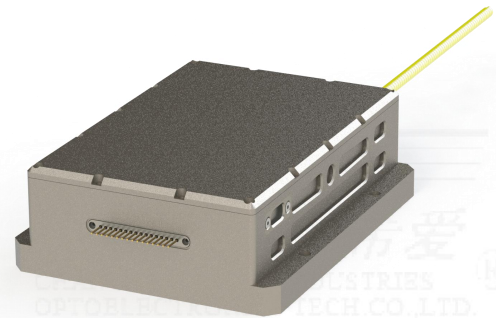

Outline Dimension (mm)

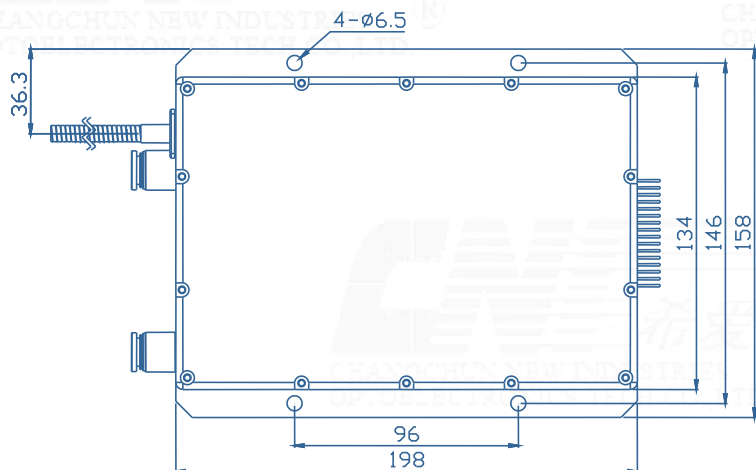
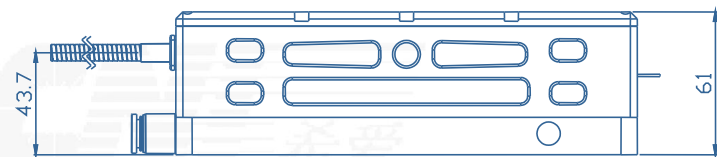
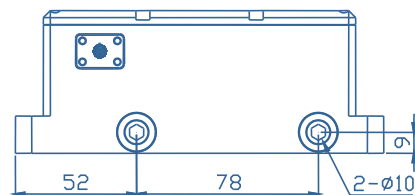
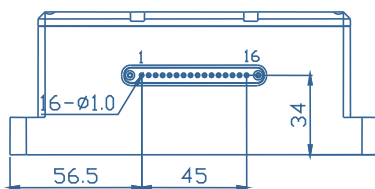

Pin-out Assignment

Pin	Function	Pin	Function
1	LD1(+)	9	LD5(+)
2	LD1(-)	10	LD5(-)
3	LD2(+)	11	LD6(+)
4	LD2(-)	12	LD6(-)
5	LD3(+)	13	LD7(+)
6	LD3(-)	14	LD7(-)
7	LD4(+)	15	LD8(+)
8	LD4(-)	16	LD8(-)

Typical Device Performance (20°C)

	Min	Typical	Max	Unit
Optical				
CW Output Power	-	70	-	W
Center Wavelength	-	520±10	-	nm
Spectral Width (90% of Power)	-	4.0	-	nm
Electrical*				
Threshold Current	0.15	-	0.50	A
Operating Current	-	1.9	2.3	A
Operating Voltage	-	65	70	V
Slope Efficiency	-	11	-	W / A
Power Conversion Efficiency		14	-	%
Power supply mode		8 channels		
Aiming laser				
CW Output Power	-	-	-	mW
Center Wavelength	-	-	-	nm
Operating Current	-	-	-	mA
Operating Voltage	-	-	-	V
Fiber*				
Fiber Core Diameter	-	200	-	μm
Numerical Aperture	-	0.22	-	-
Fiber Length	-	1-5	-	m
Fiber Connector	-	D80/SMA905	-	-
Water Cooling				
Cooling Capacity		500		W
Minimum Flow Rate		2.0		L/min
Water Pressure		0.3		Mpa
Temperature		25		°C
PH		5.6~7.9		
Water Quality		RO/DH2O		

* Customized fiber and connector available.

Absolute Ratings

	Min	Max	Unit
Operating Temperature	15	35	°C
Operating Relative Humidity	-	75	%
Storage Temperature	-20	80	°C
Storage Relative Humidity	-	90	%

* Measuring specifications.

All figures in this specification are measured by CNI's method and may contain measurement deviations.

The above specifications are for reference purpose only and subjected to change without prior notice.

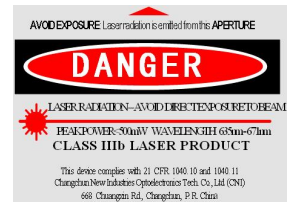

Changchun New Industries Optoelectronics Tech. Co., Ltd
<http://www.cnilaser.com>

◆ CONTACT

No.668, Chuangxin Road, High-tech zone,
Changchun 130012, China

Phone: 0086-431-85603799

Fax: 0086-431-87020258