



LDM-878.6-72

Typical Device Performance (25°C)

Optical	Unit	Typical Value
CW Output Power	W	72
Center Wavelength	nm	878.6±0.5
Spectral Width (90% of Power)	nm	<0.5
Wavelength Shift with Temperature	nm / °C	0.02
Wavelength Shift with Current	nm / A	0.05
Feedback Protection (1030-1100nm)	dB	>40
Electrical		
Threshold Current	A	1.0
Operating Current	A	9.5
Operating Voltage	V	16.0
Slope Efficiency	W / A	9.8
Power Conversion Efficiency	%	45
Fiber*		
Fiber Core Diameter	μm	400
Fiber Cladding Diameter	μm	440
Fiber Buffer Diameter	μm	700
Numerical Aperture	-	0.22
Fiber Length	m	1.0
Fiber optic connector	-	SMA905

* Customized fiber and connector available.

Absolute Ratings

	Min	Max	Unit
Operating Temperature	10	40	°C
Operating Relative Humidity	-	75	%
Storage Temperature	-20	80	°C
Storage Relative Humidity	-	90	%
Lead Soldering Temperature, 10 s max	-	250	°C

Addr: No.888 Jinhua Road High-tech Zone, Changchun 130103, P.R.China

Contact: sales@cnilaser.com International Tel: +86-431-85603799 Fax: +86-431-87020258

Characteristics of 878.6nm-72W laser diode module (25°C)

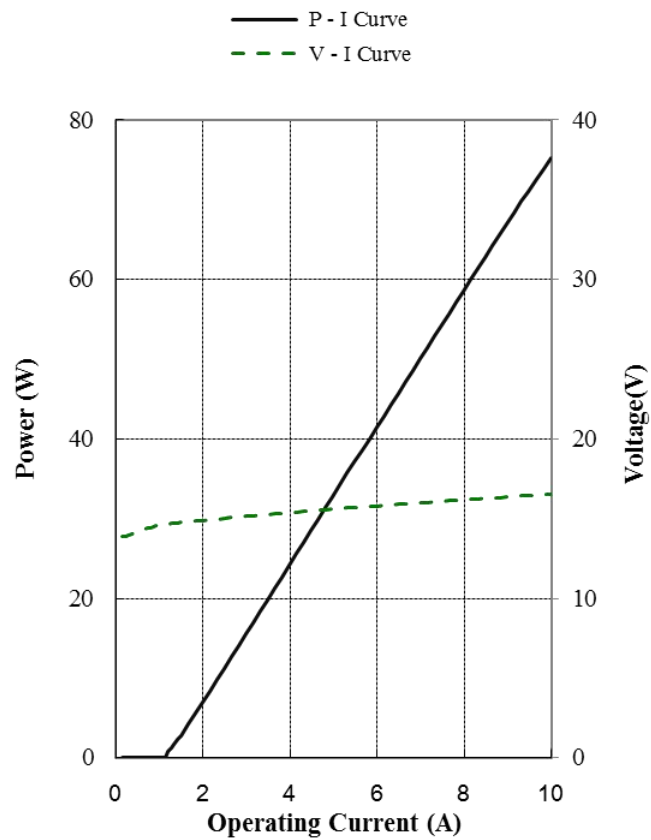

Typical spectrum of 878.6nm-72W laser diode module (25°C)

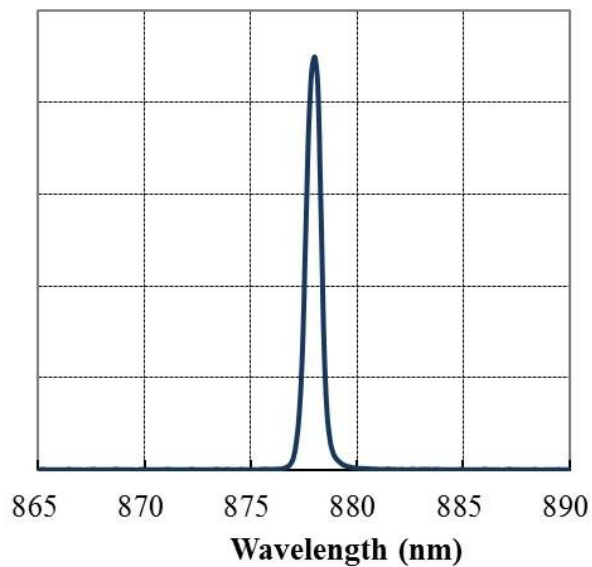

Addr: No.888 Jinhua Road High-tech Zone, Changchun 130103, P.R.China

Contact: sales@cnlaser.com International Tel: +86-431-85603799 Fax: +86-431-87020258

Package Dimensions (mm)

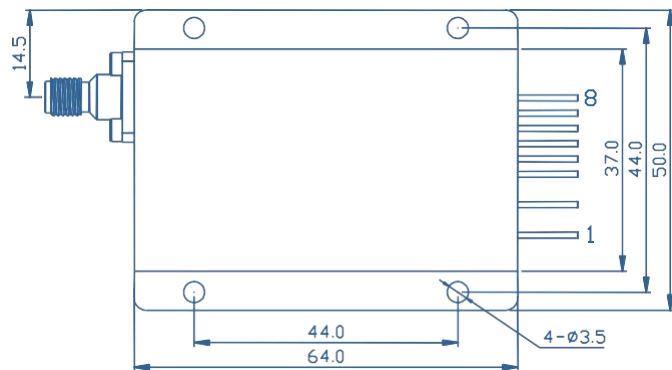
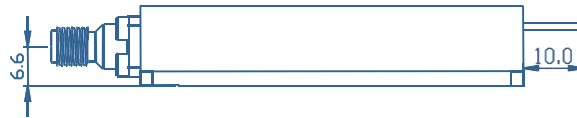
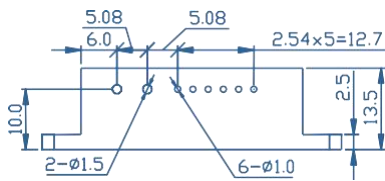

Addr: No.888 Jinhua Road High-tech Zone, Changchun 130103, P.R.China

Contact: sales@cnilaser.com International Tel: +86-431-85603799 Fax: +86-431-87020258