

MBL-SF-430/1~100mW

SPECIFICATIONS

LD PUMPED ALL-SOLID-STATE
BLUE LASER

All solid state 430nm blue laser is made features of ultra compact, long lifetime, low cost and easy operating, which is used in laser display, medical treatment, scientific research, etc.



Wavelength (nm)	430±2
Operating mode	CW
Output power (mW)	>10, 20, 50, ..., 100
Power stability (rms, over 4 hours)	<3%, <5%
Transverse mode	Near TEM ₀₀
Beam divergence, full angle (mrad)	<2
Beam diameter at the aperture (1/e ² , mm)	~5
Polarization ratio	>100:1
Beam height from base plate (mm)	100
Warm-up time (minutes)	<10
Operating temperature (°C)	15~30
Power supply (90-264VAC)	PSU-W-FDA
Expected lifetime (hours)	10000
Warranty period	1 year

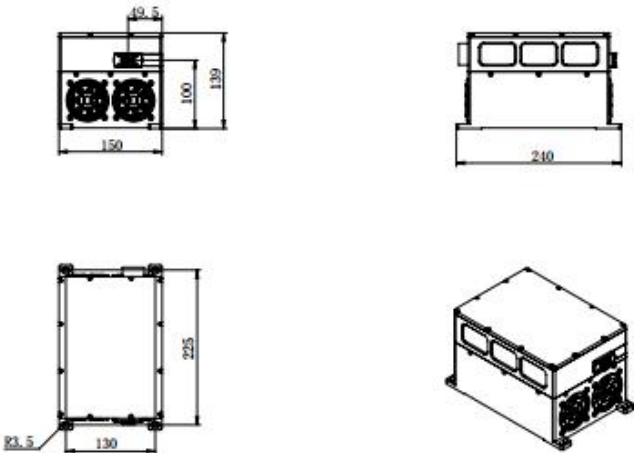
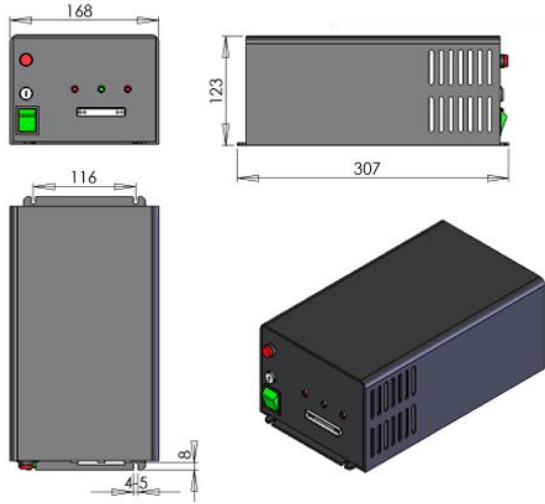

MBL-SF-430	PSU-W-FDA
 <p>240(L)×150(W)×139(H) mm³, 7.5kg</p>	 <p>307 (L) ×168(W) ×123(H) mm³, 4.5kg</p>