

MDL-HF-852/1~50mW



HIGH FREQUENCY DIODE LASER AT 852nm

This series laser products with excellent material removal rate, are widely used in microelectronics, material processing, solar energy and medical equipment manufacturing, etc.



SPECIFICATIONS

Central wavelength (nm)	852±10
Output power (mW)	>1, 10, 20, ...,50
Power stability (rms, over 4 hours)	<1%, <2%, <3%
Transverse mode	Near TEM ₀₀
Noise of amplitude(rms, CW)	<1%
M ² factor	<1.5
Beam diameter at the aperture (1/e ² ,mm)	~4.0
Beam divergence, full angle (mrad)	<1.0
Warm-up time (minutes)	<2
Beam height from base plate (mm)	19
Operating temperature (°C)	10~35
Input voltage	+12VDC
Maximum bandwidth (MHz)	>30
Rise Time (ns)	<4
Fall Time (ns)	<3
Modulation Depth (extinction ratio)	>1000000:1
Expected lifetime (hours)	10000
Warranty	1 year

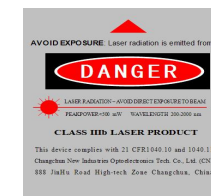

MDL-HF-852

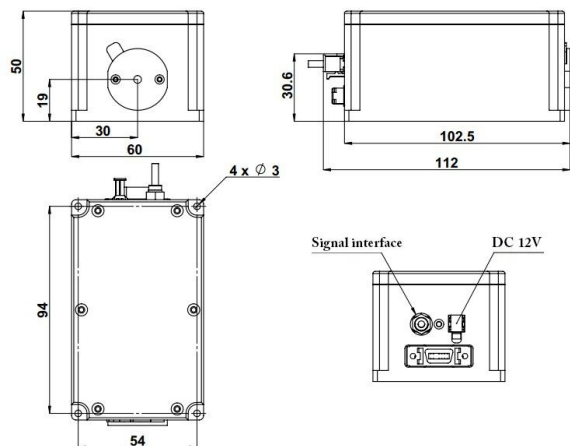

112(L) × 60(W) × 50(H) mm³, 0.5kg

Optional Power Supply

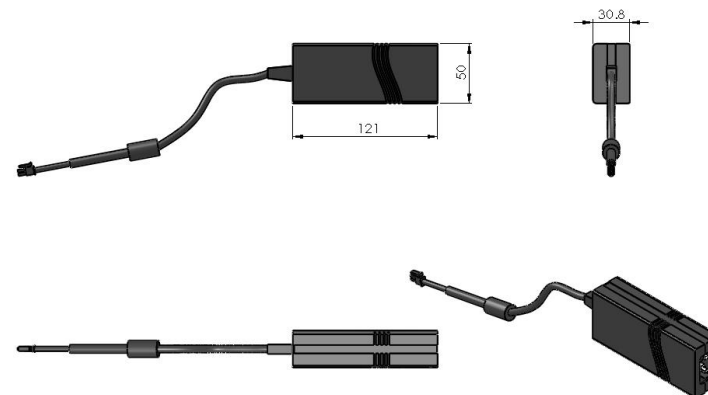

121(L) × 50(W) × 30.8 (H) mm³, 0.3kg