

MGL-N-515/100~150mW



LD PUMPED ALL-SOLID-STATE GREEN LASER

All solid state 515nm green laser is made features of ultra compact, long lifetime and easy operating, which is widely used in collimation, laser medical treatment, scientific experiment, optical instrument, etc.



SPECIFICATIONS

| | | |
|---|--|-----------|
| Wavelength (nm) | 515±1 | |
| Operating mode | CW | |
| Output power (mW) | >100, 110, 120, ..., 150 | |
| Power stability (rms, over 4 hours) | <5%, <3% | |
| Transverse mode | TEM ₀₀ | |
| M ² factor | <1.2 | |
| Beam divergence, full angle (mrad) | <1.2 | |
| Beam diameter at the aperture (1/e ² , mm) | ~2.0 | |
| Warm-up time (minutes) | <10 | |
| Polarization ratio | >100:1 | |
| Beam height from base plate (mm) | 68.4 | |
| Operating temperature (°C) | 10~35 | |
| Power supply (90-264VAC) | PSU-H-LED | PSU-H-FDA |
| TTL / Analog modulation | TTL or Analog with 1Hz-1kHz 1kHz-10kHz, 10kHz-30kHz optional | |
| Expected lifetime (hours) | 10000 | |
| Warranty period | 1 year | |

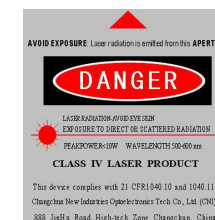

MGL-N-515

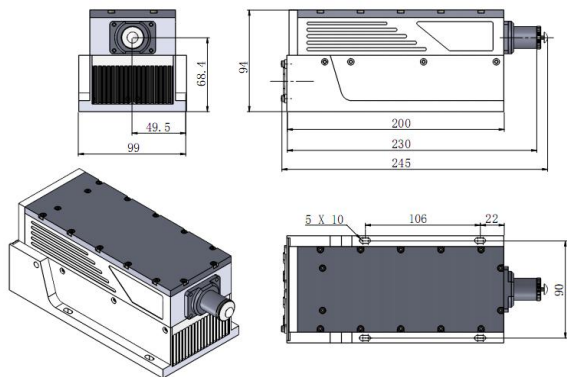

245 (L) × 99 (W) × 94 (H) mm³, 2.6 kg

PSU-H-LED



275.5 (L) × 145 (W) × 106 (H) mm³, 2.5 kg

PSU-H-FDA

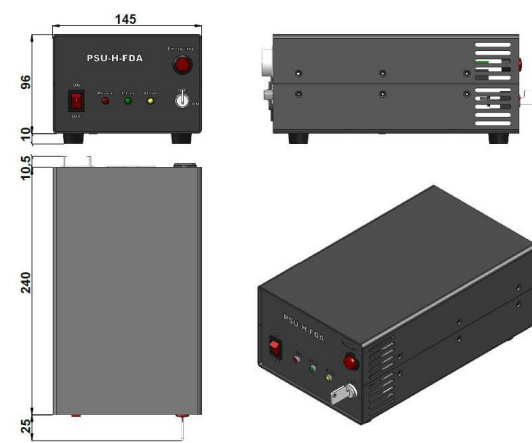

275.5 (L) × 145 (W) × 106 (H) mm³, 2.5 kg