

MIL-W-2700/2803/2830/10~40μJ

LD PUMPED ALL-SOLID-STATE INFRARED LASER

CNI's infrared laser with three wavelength at 2700nm, 2803nm and 2830nm is always called waterlase. It is made features of good beam quality and easy operating which is widely used in medical treatment in which it can perform many procedures without a shot or a drill.

SPECIFICATIONS

Wavelength (nm)	2700±2, 2803±5, 2830±3
Output power (μJ)	>10, 20, ...40
Operating mode	TTL
Rep. rate (Hz)	10, 20, ...1000
Power stability (rms, over 4 hours)	<3%
Warm-up time (minutes)	<10
Beam divergence, full angle (mrad)	<8
Beam diameter at the aperture (mm)	<1
Beam height from base plate (mm)	45
Operating temperature (°C)	10~30
Power supply (90-264VAC)	PSU-H-LED
Expected lifetime (hours)	10000
Warranty period	1 year

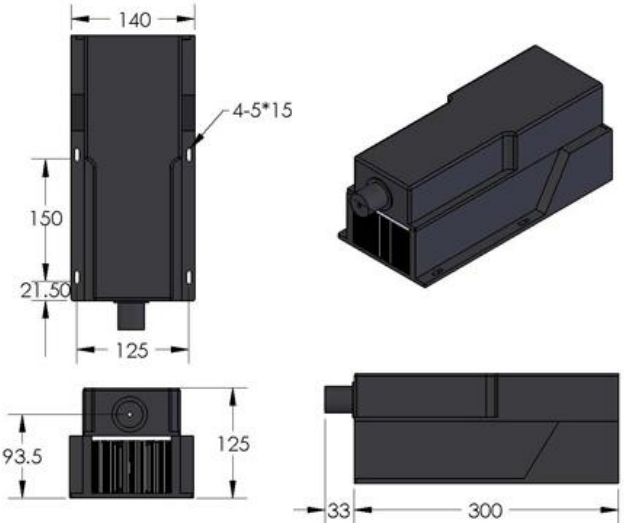
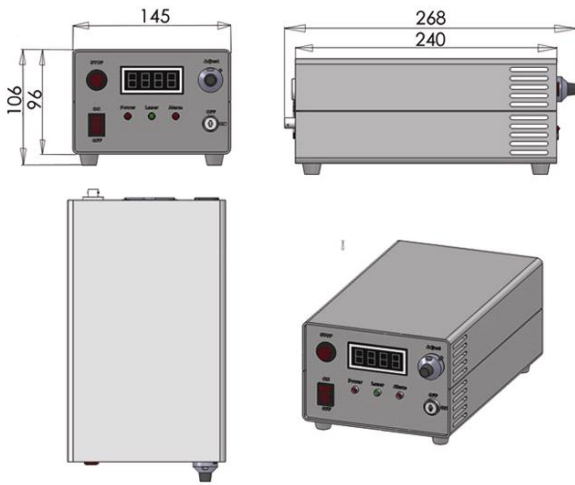

MIL-W-2700/2803/2830	PSU-H-LED
 <p>333(L)×140(W)×125(H) mm³, 6.1 kg</p>	 <p>268 (L) ×145(W) ×106 (H) mm³, 2.6 kg</p>