

MLL-III-400/405



LOW NOISE VIOLET DIODE LASER AT 400/405nm

It features ultra compact design, long lifetime, cost-effectiveness and easy operation. They are used in measurement, communication, spectrum analysis, etc.



SPECIFICATIONS

Model	MLL-III-400	MLL-III-405
Central wavelength (nm)	400±5	405±5
Operating mode	CW	
Output power (mW)	>1, 2, 3, ...,300	>1, 2, 3, ...,500
Power stability (rms, over 4 hours)	<1%, <2%, <3% (<0.5%, optional)	
Transverse mode	Near TEM ₀₀	
Noise of amplitude (rms, 20Hz~20MHz)	<1%	
M ² factor	<1.5 (<1.2, optional)	
Beam diameter at the aperture (1/e ² ,mm)	~2.5 (~1.2, optional)	
Beam divergence, full angle (mrad)	0.5	
Polarization ratio	>50:1 (>100:1, optional) Horizontal±5 degree (Vertical Optional)	
Warm-up time (minutes)	<5	
Pointing stability after warm-up (mrad)	<0.05	
Beam height from base plate (mm)	24.8	
Operating temperature (°C)	10~35	
Power supply	85-264VAC	PSU-III-LED/ PSU-III-FDA (Frequency for 1Hz-30kHz)
	100-240VAC	PSU-A-D (Frequency for 30kHz -100kHz)
TTL / Analog modulation	TTL or Analog with 1Hz-1kHz 1kHz-10kHz, 10kHz-30kHz, 30kHz-100kHz optional	
Expected lifetime (hours)	10000	
Warranty	1 year	

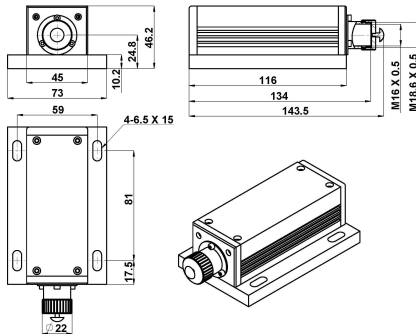
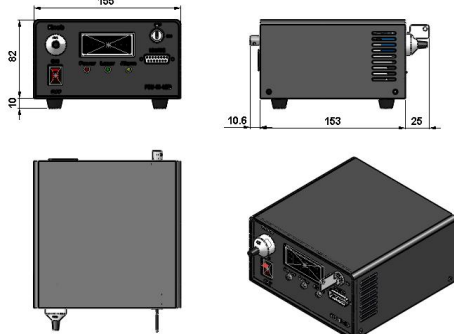
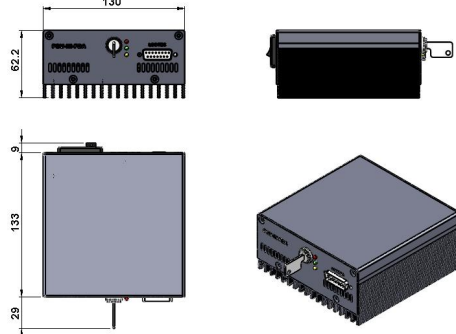
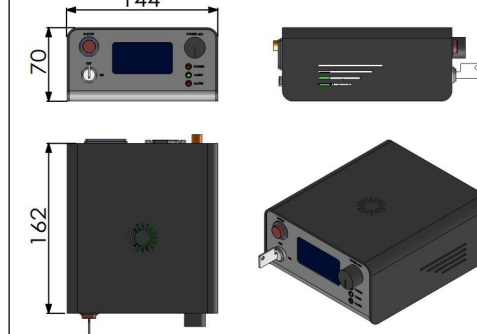

MLL-III-400/405	PSU-III-LED	PSU-III-FDA	PSU-A-D
 <p>143.5(L)×73(W)×46.2(H) mm³, 0.7kg</p>	 <p>188.6 (L)×155(W)×92 (H) mm³, 1.5kg</p>	 <p>171(L)×130(W)×62.2 (H) mm³, 1.2kg</p>	 <p>162(L)×144(W)×70 (H) mm³, 1.0kg</p>