

**MPL-F-351/0.1~4uJ/1~10mW**



**LD PUMPED ALL-SOLID-STATE  
UV LASER**

All solid state 351 nm UV laser is made features of ultra compact, long lifetime, low cost and easy operating, which is widely used in UV curing, micro-electronics, CD carving, laser medical treatment, scientific experiment, etc.



**SPECIFICATIONS**

Central wavelength (nm)		351±1
Output average power (mW)		1~10
Transverse mode		Near TEM <sub>00</sub>
Operating mode		Frequency conversion of Q-switched pulsed laser
Single pulse energy (μJ)		0.1~4
Pulse duration (ns)		~4
Peak power(W)		25~1000
Rep. rate (kHz)	Controllable	Specified One rep. rate, such as 0.1Hz, 100 Hz, 500 Hz up to1kHz, with stable laser pulses emitting (stable pulse energy, peak, duration and period). Different rep. rate in the range of 0.1Hz to1kHz can be obtained by input an external TTL signal.
	Uncontrollable	QCW state with one rep. rate between2kHz-3kHz.
Average power (mW)		Average power (mW) = Single pulse energy (μJ) * Rep. rate (kHz)
Ave power stability (over 4 hours)		<5%, <10%
Beam divergence, full angle (mrad)		<1.5
Beam diameter at the aperture (mm)		~2.0
Polarization ratio		>50:1
Pointing stability after warm-up (mrad)		<0.05
Warm-up time(minutes)		<10
Beam height from base plate (mm)		45
Operating temperature (°C)		10~35
Spectral purity		>99%
Power supply (90-264VAC)		PSU-H-FDA
Expected lifetime (hours)		5000
Warranty period		1 year
Remarks		Please Note: because of the Walk-off effect of Nonlinear crystals, the beam quality of UV laser is not so good as that of 1053/526nm laser.



**MPL-F-351**

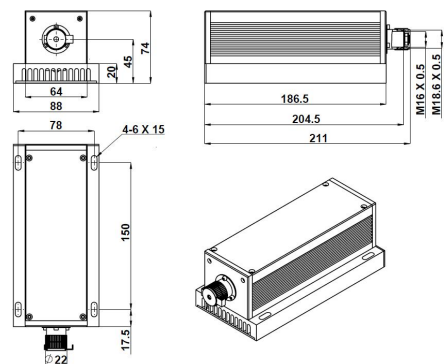

211 (L)×88(W) ×74(H) mm<sup>3</sup>, 1.6 kg

**PSU-H-FDA**

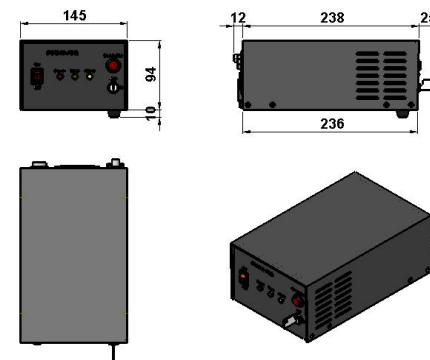

275(L) ×145(W) ×104(H) mm<sup>3</sup>, 2.3 kg