



MPL-F-355/0.1~15uJ/1~100mW



LD PUMPED ALL-SOLID-STATE  
UV LASER

All solid state 355 nm UV laser is made features of ultra compact, long lifetime, cost-effectiveness and easy operating, which is widely used in UV curing, micro-electronics, CD carving, laser medical treatment, scientific experiment, etc.



SPECIFICATIONS

Central wavelength (nm)	355±1	
Output average power (mW)	1~100	
Transverse mode	Near TEM <sub>00</sub>	
Operating mode	Frequency conversion of Q-switched pulsed laser	
Single pulse energy (μJ)	0.1~15	
Pulse duration (ns)	~5	
Peak power(W)	20~3000	
Rep. rate (kHz)	FIXED	Setting up one fixed rep. rate internal between 1kHz-4kHz with stable pulse energy, pulse duration and pulse period.
	EXT TRIG	1kHz-4kHz by external trigger with stable pulse energy, pulse duration and pulse period.
	QCW	QCW state with one rep. rate between 5kHz-10kHz.
Average power (mW)	Average power (mW) = Single pulse energy (μJ) * Rep. rate (kHz)	
Ave power stability (over 4 hours)	<5%, <10%	
Beam divergence, full angle (mrad)	<1.5	
Beam diameter at the aperture (mm)	~2.0	
Polarization ratio	>100:1	
Pointing stability after warm-up (mrad)	<0.05	
Warm-up time(minutes)	<10	
Beam height from base plate (mm)	45	
Operating temperature (°C)	10~35	
Spectral purity	>99%	
Power supply (90-264VAC)	PSU-H-FDA	
Expected lifetime (hours)	5000	
Warranty period	1 year	
Remarks	Please Note: because of the Walk-off effect of Nonlinear crystals, the beam quality of UV laser is not so good as that of 1064/532nm laser.	

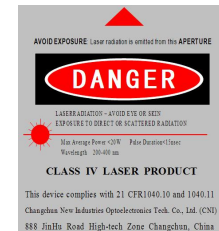

MPL-F-355

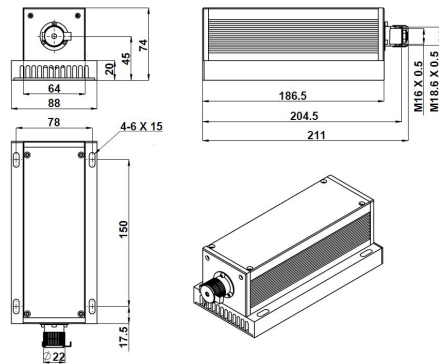

211 (L)×88(W)×74(H) mm<sup>3</sup>, 1.6 kg

PSU-H-FDA

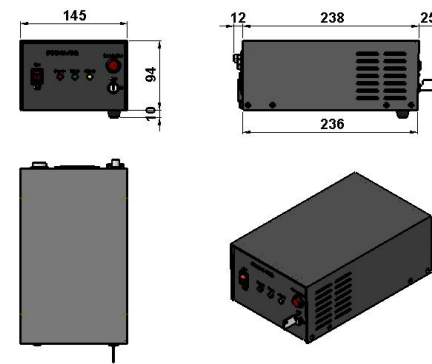

275(L)×145(W)×104(H) mm<sup>3</sup>, 2.3 kg