

MPL-H-1313/10~20uJ/1~100mW



LD PUMPED ALL-SOLID-STATE
Q-switched LASER

All solid state Q-switched laser at 1313 nm has the features of high peak power, high repetition rate, and short pulse duration, which is widely used in industry, scientific research, etc.



SPECIFICATIONS

Central wavelength (nm)		1313±1
Operating mode		Q-switched pulsed laser
Max average power (mW)		100
Single pulse energy (μJ)		10~20
Pulse duration (ns)		~18
Peak power (W)		560~1100
Rep. rate (kHz)	FIXED	Setting up one fixed rep. rate internal between 1Hz-4kHz with stable pulse energy, pulse duration and pulse period.
	EXT TRIG	1Hz-4kHz by external trigger with stable pulse energy, pulse duration and pulse period.
	QCW	QCW state with one rep. rate between 5kHz-6kHz.
Average power (mW)		Average power (mW) = Single pulse energy (μJ) * Rep. rate (kHz)
Ave power stability (over 4 hours)		<1%, <2%, <3%, <5%
Transverse mode		Near TEM ₀₀
M ² factor		<1.5
Beam diameter at the aperture(1/e ² ,mm)		~3.0
Beam divergence, full angle (mrad)		<2.0
Warm-up time (minutes)		<10
Beam height from base plate (mm)		29
Operating temperature (°C)		10~35
Power supply (90-264VAC)		PSU-H-FDA
Expected lifetime (hours)		10000
Warranty		1 year
Remarks		UV laser at 266nm or 355nm can be generated by MPL-H-1064 or MPL-H-532.

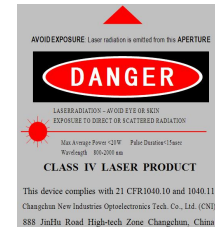

MPL-H-1313

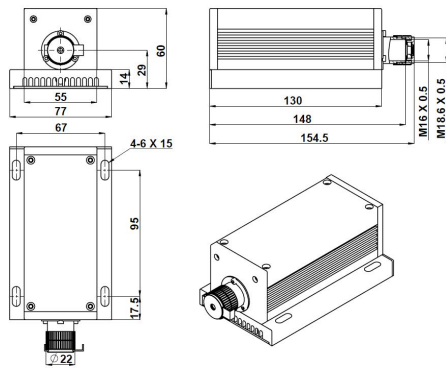

154.5(L)×77(W)×60(H) mm³, 0.9 kg

PSU-H-FDA

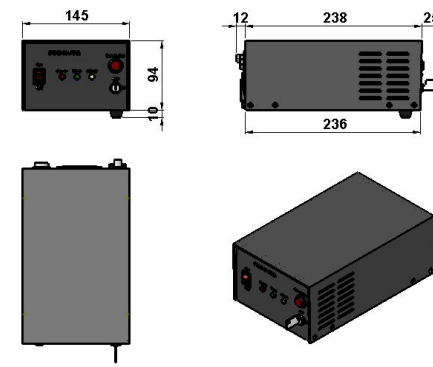

275(L)×145(W)×104(H) mm³, 2.3 kg