

MPL-H-532/5~50uJ/30-150mW



LD PUMPED ALL-SOLID-STATE Q-SWITCHED LASER

All solid state Q-switched laser at 532nm has the features of high peak power, high repetition rate, and short pulse duration, which is widely used in industry (marking on the diamond or stone), teaching of nonlinear optics, experiments of generating 355nm, or 266nm laser, fiber communication, etc.



SPECIFICATIONS

Central wavelength (nm)		532±1
Operating mode		Frequency conversion of Q-switched pulsed laser
Single pulse energy (μJ)	5~50	~30
Pulse duration (ns)	~5	~1.3
Peak power (W)		1000~10000 23000
Rep. rate (kHz)	FIXED	Setting up one fixed rep. rate internal between 1Hz-4kHz with stable pulse energy, pulse duration and pulse period.
	EXT TRIG	1Hz-4kHz by external trigger with stable pulse energy, pulse duration and pulse period.
	QCW	QCW state with one rep. rate between 5kHz-30kHz.
Average power (mW)		Average power (mW) = Single pulse energy (μJ) * Rep. rate (kHz)
Ave power stability (over 4 hours)		<1%, <2%, <3%, <5%
Transverse mode		TEM ₀₀
Warm-up time (minutes)		<10
M ² factor		<1.5
Beam divergence, full angle (mrad)		<1.5
Beam diameter at the aperture (mm)		~1
Beam height from base plate (mm)		29
Operating temperature (°C)		10~35
Power supply (90-264VAC)		PSU-H-FDA
Expected lifetime (hours)		10000
Warranty period		1 year
Remarks		UV laser at 266nm or 355nm can be generated by MPL-H-1064 or MPL-H-532 by frequency doubler.

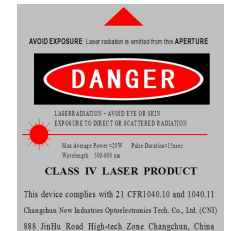

MPL-H-532

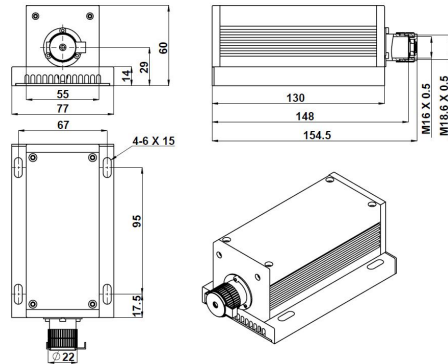

154.5(L)×77(W)×60(H) mm³, 0.9 kg

PSU-H-FDA

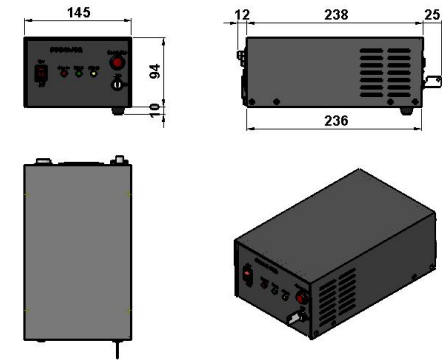

275(L)×145(W)×104(H) mm³, 2.3 kg