

MPL-III-1319/1-6uJ/1-100mW



LD PUMPED ALL-SOLID-STATE Q-SWITCHED LASER

All solid state Q-switched laser at 1319nm has the features of high peak power, high repetition rate, and short pulse duration, which is widely used in industry (marking on the diamond or stone), teaching of nonlinear optics, fiber communication, etc.



SPECIFICATIONS

Central wavelength (nm)		1319±1
Operating mode		Q-switched pulsed laser
Single pulse energy (μJ)		1~6
Pulse duration (ns)		~10
Peak power (W)		100~600
Rep. rate (kHz)	FIXED	Setting up one fixed rep. rate internal between 1kHz-4kHz with stable pulse energy, pulse duration and pulse period.
	EXT TRIG	1kHz-4kHz by external trigger with stable pulse energy, pulse duration and pulse period.
	QCW	QCW state with one rep. rate between 10kHz-20kHz.
Average power (mW)		Average power (mW) = Single pulse energy (μJ) * Rep. rate (kHz)
Ave power stability (over 4 hours)		<1%, <2%, <3%, <5%
Transverse mode		TEM ₀₀
Warm-up time (minutes)		<10
Beam divergence, full angle (mrad)		<1.5
Beam diameter at 1/e ² (mm)		~1.5
Beam height from base plate (mm)		24.8
Operating temperature (°C)		10~35
Power supply (90-264VAC)		PSU-III-FDA
Expected lifetime (hours)		10000
Warranty		1 year

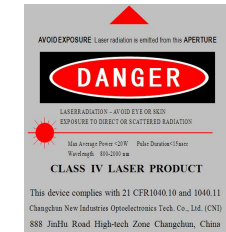

MPL-III-1319

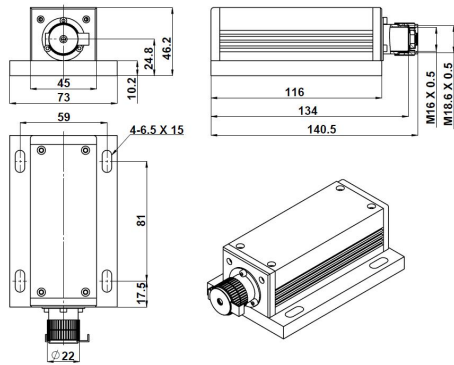

140.5 (L) × 73 (W) × 46.2 (H) mm³, 0.6kg

PSU-III-FDA

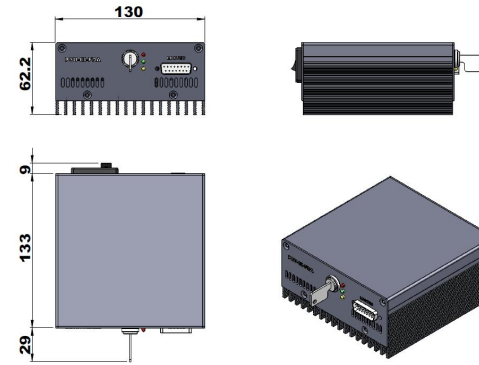

171 (L) × 130 (W) × 62.2 (H) mm³, 1.2kg