

MPL-N-257/0.1~4uJ/1~15mW



**LD PUMPED
ALL-SOLID-STATE
UV LASER**

All solid state 257 nm UV laser is made features of ultra compact, long lifetime, cost-effectiveness and easy operating, which is widely used in UV curing, micro-electronics, CD carving, laser medical treatment, scientific experiment, etc.



SPECIFICATIONS

Central wavelength (nm)	257±1
Output average power (mW)	1~15
Transverse mode	Near TEM ₀₀ , elliptical
Operating mode	Pulsed, Cr : YAG passively Q-switched
Single pulse energy (μJ)	0.1~4
Pulse duration (ns)	~10
Peak power (W)	~400
Rep. rate (kHz)	QCW state with one rep. rate between 2kHz-5kHz.
Average power (mW)	Average power (mW) = Single pulse energy (μJ) * Rep. rate (kHz)
Ave power stability (over 4 hours)	<10%
Beam parameters	Elliptical (4:1), Beam spot 0.5*2mm
Warm-up time (minutes)	<10
Beam height from base plate (mm)	70
Operating temperature (°C)	10~35
Power supply (90-264VAC)	PSU-H-FDA
Cooling system	Air
Expected lifetime (hours)	5000
Warranty period	1 year
Remarks	Please Note: because of the Walk-off effect of Nonlinear crystals, the beam quality of UV laser is not so good as that of 1064/532nm laser.



MPL-N-257

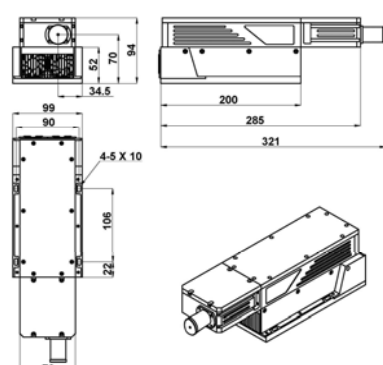

321(L)×99(W)×94(H) mm³, 3.215 kg

PSU-H-FDA

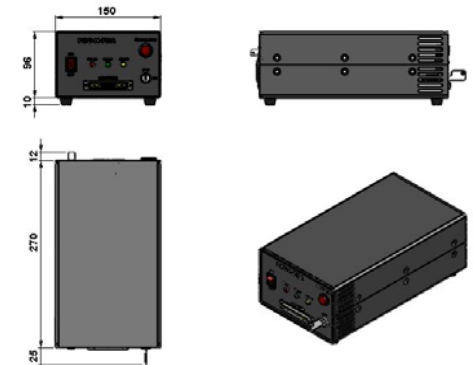

307 (L) ×150(W) ×106 (H) mm³, 2.9 kg