



OEM-D-635 /1-2W

**RED DIODE LASER
At 635nm**

OEM diode red laser at 635nm is made features of ultra compact, long lifetime, low cost and easy operating, which is widely used in measurement, spectrum analysis, laser lighting show, etc.



SPECIFICATIONS

Wavelength (nm)	635±5	
Operating mode	CW	
Output power (W)	>1, ... , 2	
Power stability (rms, over 4 hours)	<1%, <3%, <5%	
Beam diameter at the aperture (mm)	~5.0×3.8	~5.5×4
Beam divergence, full angle (mrad)	<1.6×0.2	<1.6×0.4
Polarization direction	Horizontal+ Vertical	
Warm-up time (minutes)	<5	
Beam height from base plate (mm)	30 (OEM-D-635)	68.2 (D-635-HS)
Operating temperature (°C)	25+/-3 (OEM-D-635)	10-35 (D-635-HS)
Power supply (100-240VAC)	PSU-6R-OEM-H/ PSU-SD-OEM/ PSU-6R-OEM	
Modulation option	TTL/Analog 1Hz-5KHz, 1Hz-10KHz, 1Hz-100KHz, and TTL on/off	
Expected lifetime (hours)	10000	
Warranty	1 year	



Dimensions of Laser head

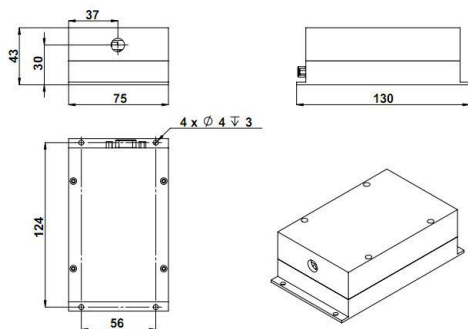

OEM-D-635

130(L)×75(W)×43(H)mm³, 1.0kg

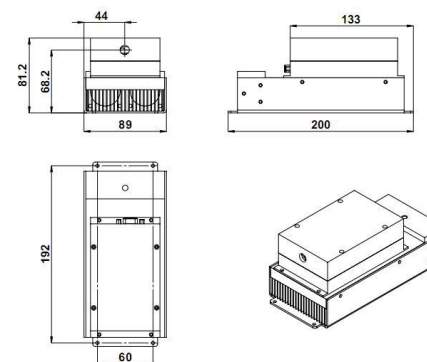

D-635-HS

200(L)×89(W)×81.2(H) mm³, 2.2kg



Power supply (1W)

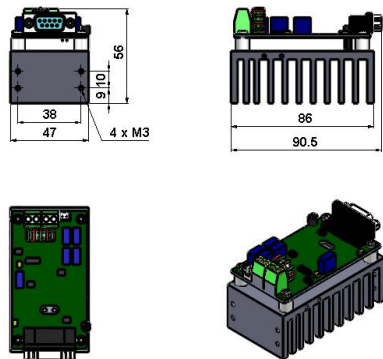

PSU-SD-OEM

90.5(L)×47(W)×56(H) mm³, 0.3kg

Adapter(1W)

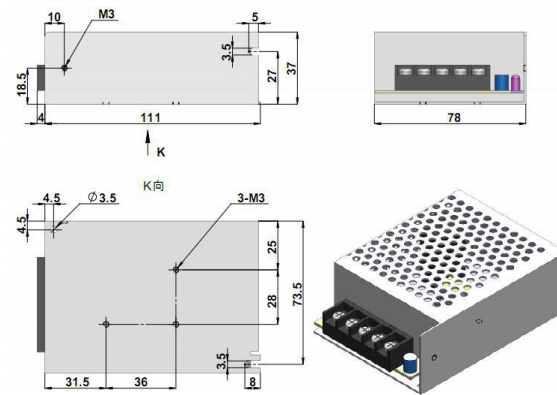

8V5A

111(L)×78(W)×37(H) mm³, 0.2kg

Power supply (2W)

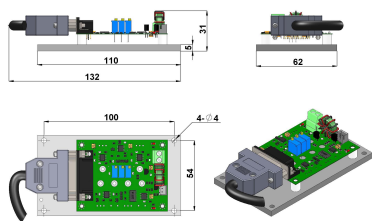

PSU-6R-OEM

110(L)×62(W)×31(H) mm³, 0.2kg

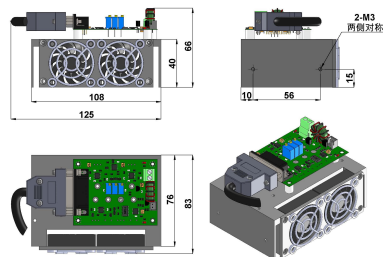

PSU-6R-OEM-H

108(L)×83(W)×66(H) mm³, 0.5kg

Adapter(2W)

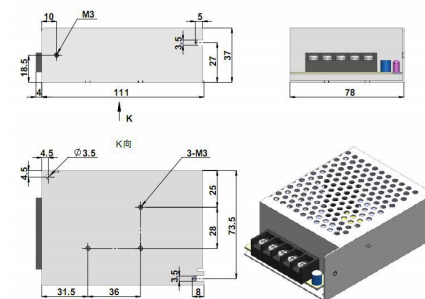

8V5A

111(L)×78(W)×37(H) mm³, 0.4kg