

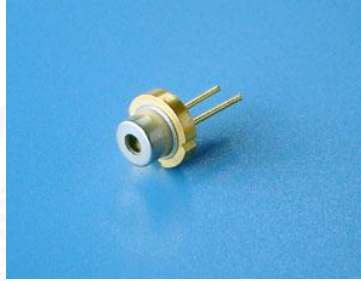

685nm Laser Diode

■ Features

- Output Power: 55mW (CW)
- Efficient Quantum Well Structure
- Standard TO-18 Package



Outline Dimension

TO-18 Package

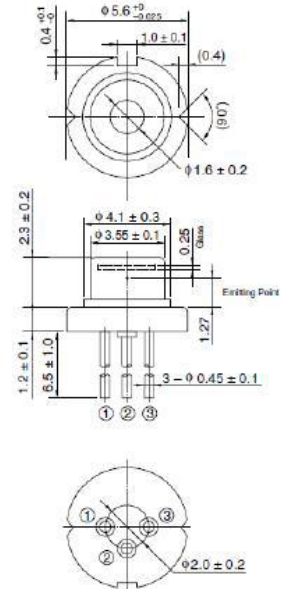

(Unit:mm)

■ Absolute Maximum Ratings

(Tc=25°C)

Item	Symbol	Absolute Maximum Ratings	Unit
Optical Output Power	Po	55	mW
LD Reverse Voltage	Vr (LD)	2	V
Storage Temperature	Tstg	-40~85	°C
Operating Case Temperature	Tc	-10~70	°C

■ Initial Electrical/Optical Characteristics

(Tc=25°C)

Item	Symbol	Typ.	Unit
Optical Output	Po	55	mW
Peak Wavelength*	λ_p	685±10	nm
Threshold Current	Ith	≤0.030	A
Operating Current	Iop	≤0.075	A
Slope Efficiency	η	≥1.1	W/A
Operating Voltage	Vop	≤2.3	V
Horizontal Beam Divergence	$\theta_{//}$	≤9	deg.
Vertical Beam Divergence	θ_{\perp}	≤21	deg.
Polarization		TE	

* Measuring specifications.

All figures in this specification are measured by CNI's method and may contain measurement deviations.

The above specifications are for reference purpose only and subjected to change without prior notice.

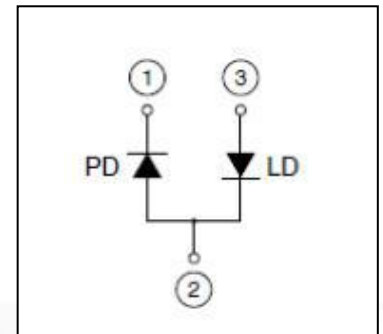

Changchun New Industries Optoelectronics Tech. Co., Ltd
<http://www.cnilaser.com>

◆ CONTACT

No.888, Jinhua Road, High-tech zone, Changchun 130103, China

Phone: 0086-431-87033597

Fax: 0086-431-87033597