

UV-C-320/1~20mW

LD PUMPED ALL-SOLID-STATE CW UV LASER

All solid state 320nm UV laser is made features of ultra compact, long lifetime, cost -effectiveness and easy operating, which is used in DNA sequencing, flow cytometry, cell sorting, optical instrument, spectrum analysis, measurement, physics experiment, laser rapid modeling, etc.



SPECIFICATIONS

Central wavelength (nm)	320±1
Operating mode	CW
Output power (mW)	>1, 2, ..., 20
Power stability (rms, over 4 hours)	<10%
Transverse mode	Near TEM ₀₀
M ² factor	<2.0
Beam diameter at the aperture (mm)	~1.5
Beam divergence, full angle (mrad)	<2.5
Polarization ratio	>50:1 Horizontal
Warm-up time (minutes)	<10
Beam height from base plate (mm)	45
Operating temperature (°C)	10~35
Spectral purity	>99%
Power supply (90-264VAC)	PSU-H-FDA
Expected lifetime (hours)	10000
Warranty period	1 year



UV-C-320

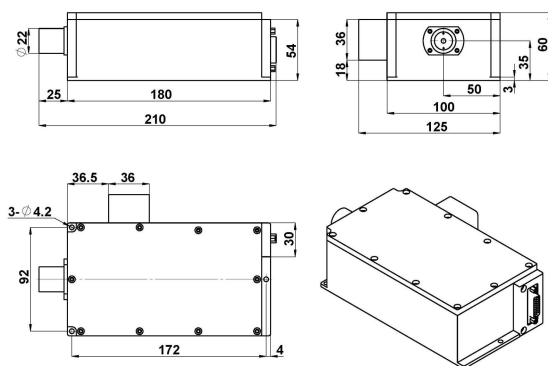

210(L)×125(W)×60(H) mm³

PSU-H-FDA

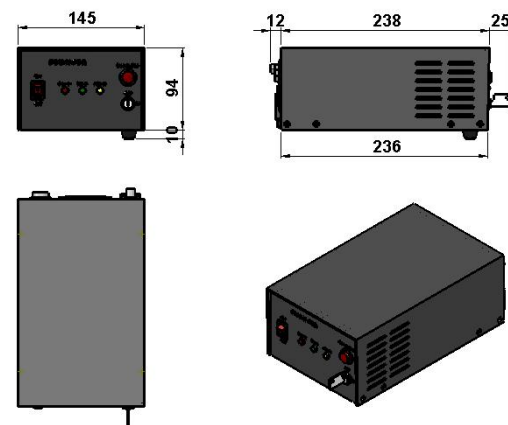

236(L) ×145(W) ×104(H) mm³, 2.3 kg