



UV-FN-360-PL /100~200mW

LD PUMPED ALL-SOLID-STATE UV LASER AT 360nm

All solid state 360nm UV laser is made features of ultra compact, long lifetime, low cost and easy operating, which is used in DNA sequencing, flow cytometry, cell sorting, optical instrument, measurement, physics experiment, laser rapid modeling, Raman spectroscopy and fluorescence analysis etc.



SPECIFICATIONS

Wavelength (nm)	360±1
Operating mode	CW
Output power (mW)	>100, 110, ... , 200
Power stability (rms, over 4 hours)	<5%, <10%
Transverse mode	Near TEM ₀₀
M ² factor	<2.0
Beam diameter at the aperture (1/e ² , mm)	~1.5
Beam divergence, full angle (mrad)	<1.0
Warm-up time (minutes)	<10
Beam height from base plate (mm)	93
Operating temperature (°C)	10~35
Power supply (90-264VAC)	PSU-H-FDA
Expected lifetime (hours)	10000
Warranty	1 year



UV-FN-360-PL

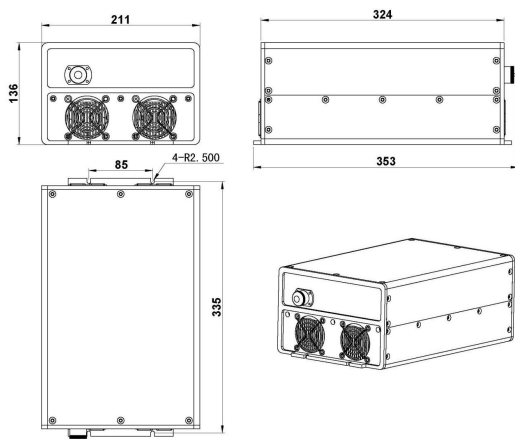

353(L)×211(W) ×136(H) mm³, 14.5 kg

PSU-H-FDA

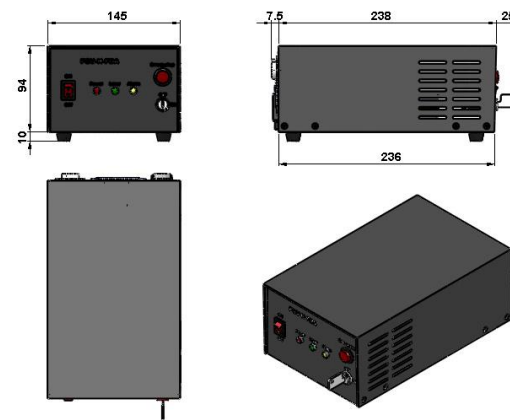

275(L) ×145(W) ×104(H) mm³, 2.3 kg