

TEM-LN-790/1-10mW



**LOW NOISE INFRARED  
DIODE LASER AT 790nm**

It features TEM<sub>00</sub> mode, ultra compact design, long lifetime, cost-effectiveness and easy operation. They are used in measurement, communication, spectrum analysis, etc.



SPECIFICATIONS

Central wavelength (nm)	790±5
Operating mode	CW
Output power (mW) <sup>1</sup>	1-10
Power stability (rms, 4 hours ± 3°C)	<2%, <1%, <0.5%
Transverse mode	TEM <sub>00</sub>
Noise of amplitude (rms, 20Hz-20MHz)	<1%, <0.5%
Ellipticity	>0.95
M <sup>2</sup>	<1.1
Beam diameter at the aperture (1/e <sup>2</sup> , mm)	~1.0
Beam divergence, full angle (mrad)	<1.5
Warm-up time (minutes)	<5
Beam height from base plate (mm)	25
Operating temperature (°C)	25±3
Power supply (100-240VAC)	PSU-III-FDA/PSU-III-LED/PSU-A-D
Modulation option	DC-1kHz, 1kHz-10kHz, 10kHz-30kHz, 30kHz-100kHz optional; TTL and Analog optional
Expected lifetime (hours)	>10000



LASER HEAD<sup>2</sup>

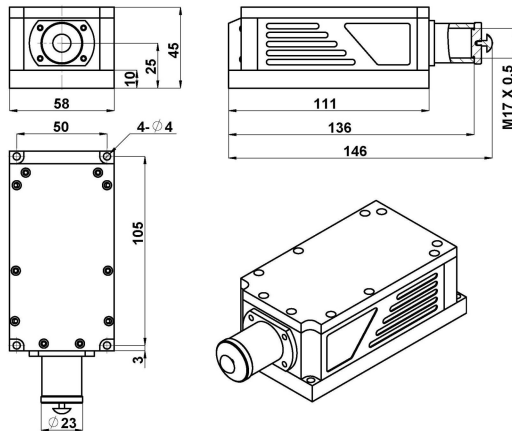

146 (L) × 58 (W) × 45 (H) mm<sup>3</sup>, 0.7kg

HEATSINK (TC-06) optional

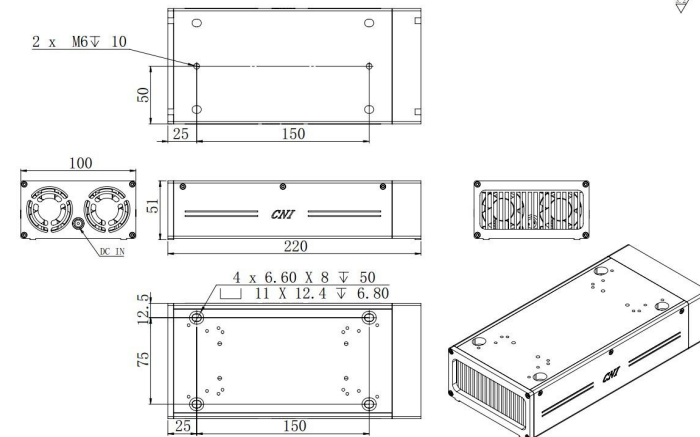

220 (L) × 100 (W) × 51 (H) mm<sup>3</sup>, 0.6kg

POWER SUPPLY (PSU-III-FDA) <sup>3</sup>	POWER SUPPLY (PSU-III-LED) <sup>4</sup>	POWER SUPPLY (PSU-A-D) <sup>5</sup>
<p>171 (L) × 130 (W) × 62.2 (H) mm<sup>3</sup>, 1.2kg</p>	<p>179 (L) × 155 (W) × 92 (H) mm<sup>3</sup>, 1.5kg</p>	<p>162 (L) × 144 (W) × 70 (H) mm<sup>3</sup>, 1.0kg</p>

- 1 Any power level can be selected in this range.
- 2 The laser head needs to be used on a heat sink with good heat dissipation.
- 3 Fixed output power; Modulation up to 30kHz.
- 4 Output power adjustable 10-100%; RS232 control optional; Modulation up to 30kHz.
- 5 Output power adjustable 10-100%; RS232 control optional; Modulation up to 100kHz.